



Filtrá

Filtrá vibración S.L.

SIEVE SHAKERS WITH 2 LATERAL ENGINES



The sieve shakers with lateral engines are made of stainless steel (AISI 304) and they specially work in reduced spaces where the input materials and the output product are closer.

These sieve shakers can be used for control and safety sieving because they have a central outlet. So they admit a great volume of product and the productivity is not affected.

Available models: FTI-2M-0550
FTI-2M-0800
FTI-2M-1200

TECHNICAL CHARACTERISTICS				
FTI-2M-0550	400-460 V	50-60 Hz	0.095-0.105 kW	1500-1800 rpm
FTI-2M-0800	400-460 V	50-60 Hz	0.180-0.190 kW	1500-1800 rpm
FTI-2M-1200	220-460 V	50-60 Hz	0.180-0.190 kW	1500-1800 rpm

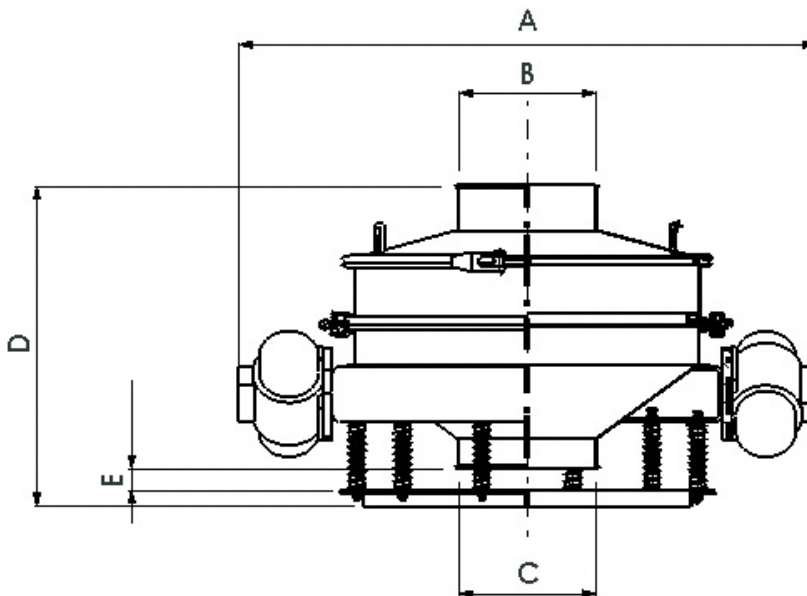

(mm)	FTI-2M-0550	FTI-2M-0800	FTI-2M-1200
A	800	1264	1655
B	Ø 100	Ø 300	Ø 300
C	Ø 200	Ø 300	Ø 300
D	500	700	849
E	40	48	50

INCLUDE:

- ▶ Sieve shaker with 2 lateral engines
- ▶ Operating instructions manual
- ▶ CE declaration of conformity